

**Users Manual**

**Phenix Technologies Inc.**



**DC DIELECTRIC TEST SET - 400P**

**MODEL 4100-10**

**VERSION 4.0**

PPD  
November, 2006

## INTRODUCTION

The DC Hipot line offered by Phenix Technologies is ruggedly built suitable for field or lab use. Designed to test electrical switchgear, cables, motors, generators, and protective equipment. DC testing is popular because the equipment is more compact and lighter in weight than comparable AC equipment.

### Design and Safety Features

- ◆ Output voltage continuously adjustable to 100kV DC.
- ◆ “Zero Start” voltage interlock and external safety interlock.
- ◆ Leakage current measurements available from .01 to 10,000 microamps DC.
- ◆ Removable line cord.
- ◆ Rotary switch selection simplifies operation.
- ◆ Integrated cable storage bin.
- ◆ Built in discharge circuit rated at 6 kilojoules.
- ◆ Light weight, portable, and enclosed in rugged, high-density polyethylene carrying case.
- ◆ Adjustable overcurrent trip point from 10%-110% of each range.
- ◆ Large, easy to read LCD meters.
- ◆ Input Circuit Breaker / Power Switch.
- ◆ Thermal resettable overload protecting high voltage transformer primary circuits.
- ◆ Very low ripple at normal hi-pot test impedances.

For full detailed specifications see Section 1-1 page 5.

# TABLE OF CONTENTS

	<u>Section Number</u>
GENERAL SAFETY PRECAUTIONS	
TECHNICAL SPECIFICATIONS	1
CONTROLS AND INDICATORS (FIGURE 1)	2
ELECTRICAL SET-UP	3
OPERATING INSTRUCTIONS	4
RETURN-GROUND-GUARD FRONT PANEL CONNECTIONS	5
CALIBRATION	6
TROUBLESHOOTING	7
STORAGE OF EQUIPMENT	8
CIRCUIT DIAGRAM SYMBOLS	9
RECOMMENDED SPARE PARTS / PARTS LIST	10
PARTS ORDERING INFORMATION	11
RETURNED MATERIAL	12
ELECTRICAL DIAGRAMS	13

## GENERAL SAFETY PRECAUTIONS



# CAUTION

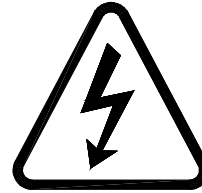

## HIGH VOLTAGE

**This equipment is capable of providing POTENTIALLY LETHAL VOLTAGES! Improper operation or test practices may result in injury or death to the operator or surrounding personnel.**

The operation of High Voltage test equipment should only be performed by personnel familiar with HIGH VOLTAGE testing and safety procedures. The operator of this equipment must be aware of all hazards associated with High Voltage testing. The operator is responsible for himself and others in close proximity of the testing area.

Some General Safety Practices for working with High Voltage Test Equipment have been listed below for your reference.

- Get familiar with your instrument before performing an actual test.
- Know your work area, check that all circuits are de-energized and locked out.
- Never work alone; always work with another qualified worker.
- Mark off entire work area with barriers and warning tape.
- Make all personnel aware of your testing activities.
- Be aware of dangerous conditions that may arise from energizing a test specimen.
- Never modify test equipment, modifications to equipment could introduce an unknown hazard or hinder a designed-in safety feature.
- DO NOT operate damaged equipment. Remove power, and do not use the equipment until safe operation can be verified by service-trained personnel.

Phenix Technologies, Inc. assumes no liability for unsafe or improper use of test equipment.

## TECHNICAL SPECIFICATIONS

### **Input**

120 VAC 10 Amps **or** 220 VAC 5 Amps, 50/60 Hz, single phase (refer to Unit Data Tag)

### **Output Rating** (maximum)

0-100 kilovolts dc

0-20 milliamperes

### **Internal Discharge Capability** 6 kilojoules

### **Duty Cycle**

Continuous – Capacitive Charging

### **Type of Cooling** Natural convection.

**Ripple** Less than 2 percent RMS at loads of 30 Megohms and higher from 10kV-100KV and capacitive loads.

**Output** Negative output, positive ground standard. Positive output available by special order. Filtered voltage doubler circuit, equivalent to full wave rectification.

### **Operating Ambient Temperature** 0 to 35 degrees Celsius.

### **Output Termination** High voltage cable, shield guarded.

### **Metering**

Output Voltmeter: 3 ½ DIGIT LCD, accuracy .5% of full scale.  
Ranges: 0 to 19.99kV, 0-100.0kV

Output Currentmeter: 3 ½ DIGIT LCD, accuracy .5% of full scale.  
Ranges of 0 to 19.99µa, 199.9µA, 1.999mA, 19.99mA

Analog Output 1.5" ANALOG

Charging Indicator: 0-100% of selected range indication.

### **Size and Weight**

22.5" W x 21" D x 16.5" H; 98\* lbs. (572 mm W x 533 mm D x 419 mm H; 44.5\* kg)

\*For 220 V units: add 10 lbs. (4.5 kg)

## CONTROLS AND INDICATORS

Refer to Figure 1.

1. **AC POWER INPUT.** Plug into a suitable grounded receptacle. See specifications tag on unit for voltage and current requirements.
2. **EXTERNAL INTERLOCK.** If desired, remove jumper from connector and replace with contact(s) that must be maintained closed during testing. Some examples include footswitch, deadman switch, gate interlock, panic button, etc.
3. **THERMAL OVERLOAD.** Circuit breaker protects primary of high voltage transformer. If circuit breaker trips, turn **High Voltage** off and return **Voltage Control** knob to zero before resetting.
4. **F1.** Control Power Fuse.
5. **MAIN POWER CIRCUIT BREAKER.** Press **I** to connect power, Press **O** to disconnect power.
6. **MAIN POWER INDICATOR.** Lights to indicate that power is available for testing.
7. **Current Trip Adjust.** Dial adjusts from 1 to 11 corresponding to approximately 10% to 110% of selected output current range. **Current Trip/Reset** lamp illuminates and high voltage turns off when output current exceeds setting, causing circuit to trip. Circuit also acts as short circuit and overload protection on high voltage output. To reactivate high voltage, **Voltage Control** must be returned to zero, and **Reset** switch must be pressed to clear **Current Trip** circuit.
8. **Reset.** **Reset** lamp illuminates to show that current trip circuit has tripped. High voltage circuits are deactivated. Momentary **Reset** switch must be pressed to extinguish **Reset** lamp to allow high voltage to be reapplied after returning **Voltage Control** to zero.
9. **High Voltage On.** Press to turn on high voltage.  
**Conditions required before high voltage will activate are:**
  - **Voltage control at Zero Start**
  - **External Interlock** loop closed.
  - **Current Trip** circuit **Reset**.
10. **High Voltage Off.** Press to turn off high voltage output. Under normal circumstances the voltage control should be returned to zero, and the high voltage allowed to decay near zero before switching **High Voltage OFF**. **CAUTION: Capacitive loads may retain voltage for a short time after high voltage is turned off while the internal circuitry bleeds their charge to ground. High Voltage Off** lamp must be illuminated before **High Voltage ON** can be activated. Conditions required for illumination are:
  - **External Interlock** loop must be closed.
  - **Overcurrent Trip/Reset** circuit must not be tripped. (Push **Reset** if circuit is tripped)

## CONTROLS AND INDICATORS

11. **Output Voltage Control.** Turn clockwise to increase output of test set. This control must be in the full counter-clockwise position (**Zero Start**) in order to turn **High Voltage On**. Under normal circumstances, **Voltage Control** should always be returned to zero and voltage displayed on the voltmeter allowed to decay to zero before pressing **High Voltage Off**.
12. **ANALOG CURRENT INDICATOR.** Meter displays current from 0-100% of range to give visual indications of capacitive charging conditions or to show changing current conditions that are not easily determined from digital meters.
13. **CURRENTMETER.** Displays current out of **High Voltage Lead** (#16) or into **Return** terminal depending upon mode of measurement
14. **VOLTMETER.** Displays voltage output of test set in kilovolts.
15. **VOLTMETER RANGE SELECTOR.** Rotate to appropriate setting for test voltage.
16. **CURRENTMETER RANGE SELECTOR.** Rotate to desired range. With capacitive loads, selector will normally be placed in highest current range and then ranged lower as appropriate.
17. **GUARD TERMINAL.** Connect to **Ground** terminal (#13) with **Grounding Clip** for **Guard Mode** operation. Connect currents that need to bypass the currentmeter to this point. Low potential side of specimen must be isolated from ground to use this mode, and will be connected to **Return** post. See section on Return – Ground – Guard for more information.
18. **GROUND (GND) TERMINAL.** Connects to facility ground. See (#12), (#14) and (#15) for more information.
19. **GROUNDING CLIP.** The **Grounding Clip** must always be connected from the **Ground** post to either the **Return** post or the **Guard** post. Do not operate the unit with the clip disconnected. See section on Return – Ground – Guard for more information.
20. **RETURN (RTN) TERMINAL.** Connect to **Ground** terminal (#13) with grounding clip for normal operation. Always connect low potential side of test specimen to this point. This is the metered connection point for measuring current. This mode must be used if low potential side of test object is grounded or has a ground reference. See section on Return – Ground – Guard for more information.
21. **HV OUTPUT LEAD.** This lead is always attached to the high potential side of the specimen under test.

**THIS PAGE  
INTENTIONALLY  
LEFT BLANK.**



Figure 1

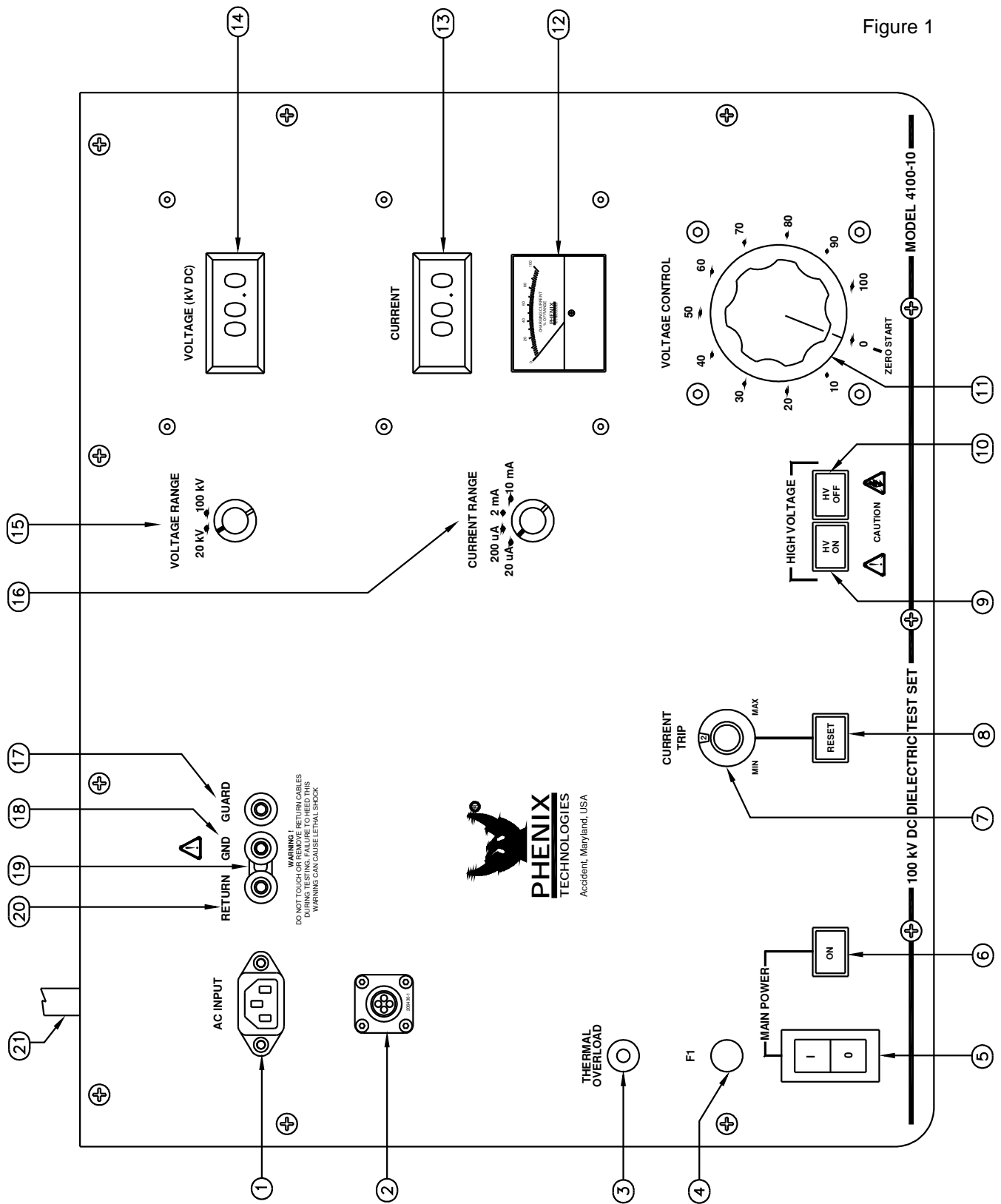

## ELECTRICAL SET-UP

1. Locate the desired location for the test set. Prepare the main power input cable for plugging into the proper facility power (i.e., 120 volts AC or 220 volts AC). Leave plug unconnected at this time.

### High Voltage Connection

**WARNING: Main Power switch on front panel must be in the OFF (O) position before proceeding. Make sure Test object is de-energized and discharged.**

1. Place currentmeter in desired mode of operation by connecting the jumper clip between Return (RTN) and Ground (GND) or Guard (GRD) and Ground (GND) binding posts. The normal connection is between Ground and Return. See Section on Return-Ground-Guard for more information on this connection.
2. Connect the Ground (GND) connection to facility ground using the ground test lead provided.
3. Connect the low potential side of test specimen to terminal labeled Return (RTN). Use red test lead provided.
4. Connect the high voltage output cable to the high potential side of test specimen. **Keep shielded part of high voltage cable away from test specimen high voltage points.**
5. Connect the input main power cable to appropriate power source. Check Technical Specifications tag on unit, for proper input voltage.
6. Read and understand entire operating instructions before applying power.

***CAUTION: Improper contact with the test leads on this equipment can cause harmful or fatal electrical shock. Do not touch test leads while a test is in process. This equipment should only be operated by someone familiar with high voltage testing and safety procedures.***

**THIS PAGE  
INTENTIONALLY  
LEFT BLANK.**

## OPERATING INSTRUCTIONS

**Caution: This equipment should only be operated by personnel familiar with high voltage testing and safety procedures. Improper operation may result in injury or death and can cause damage to the unit or test object.**

1. Ensure proper electrical set-up has been performed.
2. Check that the Voltage Control dial is set to "0" (Zero Start position).
3. Select the proper voltmeter range, currentmeter range, and current trip setting.

### **High Voltage Applied**

4. Turn on the Control Main Power switch. The Power On lamp will illuminate.
5. Momentarily press the HV On pushbutton. The high voltage will be applied to the cable and the HV On switch lamp will illuminate. (Zero Start and External Interlock Loop conditions must be met, and Reset lamp must be extinguished.
6. With HV On, rotate the Voltage Control dial and watch the Output Voltmeter and Output Currentmeter until desired levels are reached.

Note: When testing samples that are largely capacitive in nature, it may be necessary to place currentmeter range switch in the 20mA position. Operator must then slowly raise output watching the currentmeter and allowing the test sample to "charge up".

7. Record data, if desired, and lower the Voltage Control to Zero after testing is completed. Use Discharge or Grounding stick to discharge specimen or allow voltage to return to zero. Press HV Off button; high voltage will be shut off and the HV (On) switch lamp will extinguish and the High Voltage Off/Ready lamp will illuminate.

### **Overcurrent Failure**

8. If an overcurrent situation occurs (output current exceeds Overcurrent Trip setpoint), the over-current relay will activate, de-energizing the test set (High Voltage Off). To regain high voltage the Reset button must be depressed and, the Voltage Control dial must be returned to zero. Press the HV On button momentarily to turn High Voltage back on.
9. After all testing is completed; turn off the front panel Main Power switch. Remove the input power cable from the facility power input.
10. **Make certain that the test specimen is totally discharged and grounded before removing test cables.**

## OPERATING INSTRUCTIONS

**Calculating Meg-Ohms** The Impedance of a test object can be determined by the formula :

$V/I=R$  where voltage in Volts divided by current in Amps equals Resistance in Ohms.

Resistance divided by 1,000,000 then equals Meg-Ohms:  $R/1,000,000=Meg-Ohms$

When voltages are in **Kilovolts** and currents are in **Milliamps**, a more direct method is to directly divide **Kilovolts** by **Milliamps** to obtain the result directly in **Meg-Ohms**.

$KV/mA=Meg-Ohms$

**Example:** 10kv divided by 2mA equals 5Meg-Ohms

Many times though, the current will be in micro amps. In this case, micro amps must first be converted to milliamps, or the formula must be changed to accommodate micro amps. Micro amps can be converted to milliamps by dividing by 1,000.

$\mu A/1,000=mA$  Example:  $50 \mu A/1,000=0.05mA$ . The result can now be used directly in the above formula. 10kV divided by .05mA equals 200Meg-Ohms

An alternate method is to use the formula; **Kilovolts** divided by **Microamps** multiplied by **1,000** equals **Meg-Ohms**.

$KV/\mu A \times 1,000=Meg-Ohms$

**Example:** 10kV divided by 50uA times 1,000 equals 200Meg-Ohms

## RETURN-GROUND-GUARD CONNECTIONS

The unit contains a currentmeter feature useful in measurement of different current sources.

### 1. **Return Mode (RTN)** (Grounded Return Mode)

This is the standard measurement configuration. The Ground jumper is installed between the Ground (GND) post and the Return (RTN) post. The low potential side of the test specimen is connected to Return. It can initially be isolated from ground or tied to ground. When it is connected to Return in this mode, it will be grounded through the Ground jumper if it was initially isolated from ground. This mode measures all output current from the test set.

If the low potential side of the test specimen will not or can not be isolated from ground, Return mode is the hookup mode that must be used. Any connections made to Guard must be isolated from ground in this mode and will bypass the currentmeter. All currents to Ground and Return will be measured in this mode.

### 2. **Guard Mode**

In this mode, the Ground jumper is connected to the Guard post and Ground post. The low potential side of the test specimen must be isolated from ground and connected to the Return post. Only current to the Return post will be measured by the currentmeter. Any stray leakage currents to ground or from sources connected to Guard will bypass the currentmeter and not be measured such as stray leakage currents to ground, stray currents to shields or housings tied to Ground or Guard, etc. In this mode, the low potential side of the specimen must be isolated from ground. If the low potential side of the specimen can not or will not be isolated from ground, this mode can not be used to accurately measure current flow.

NOTE: Do not operate unit with the ground jumper removed or not connected to either Return or Guard. Make sure the Ground post is connected to a good earth ground. See connection diagrams on next page.

**Simplified Electrical Diagram**  
**RETURN MODE (STANDARD MODE)**

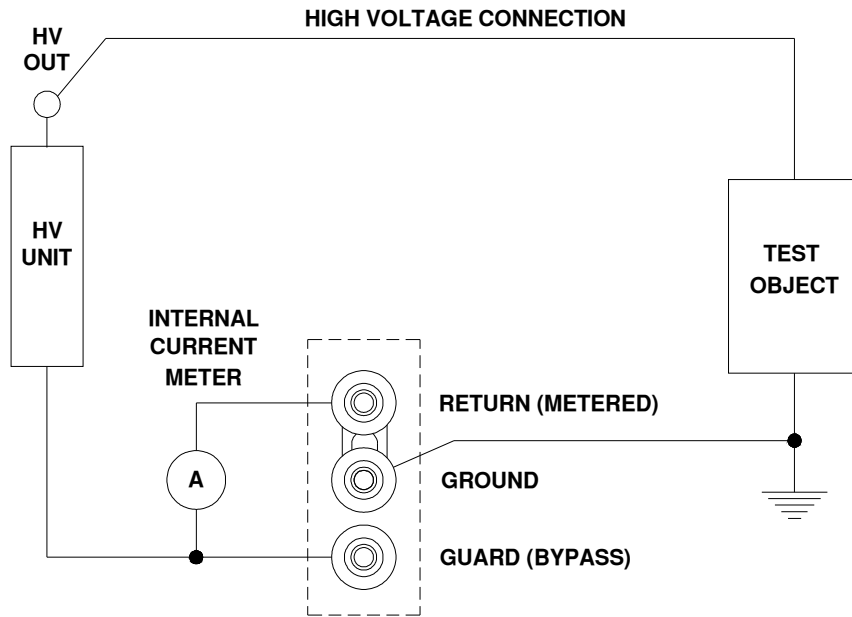

**GUARD MODE**

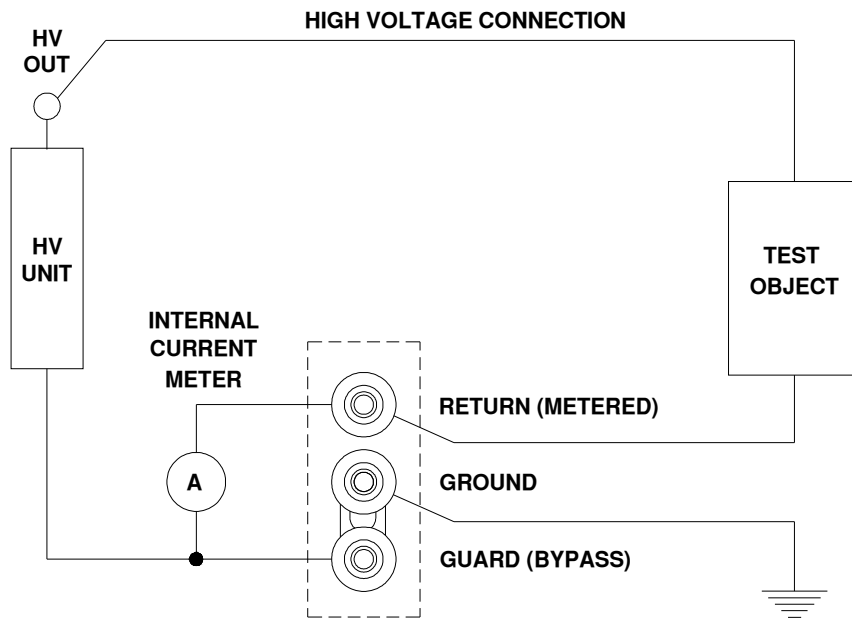

## CALIBRATION

**Caution: Calibration should only be done by persons familiar with High Voltage testing and safety procedures.**

All calibrations have been done at the factory. Periodic calibration of the output voltmeter and output currentmeter should be done approximately every six months.

NOTE: Refer to Electrical Diagram Section for schematics pertaining to the model number of your test set.

### Locating the Calibration Adjustments

The calibration points are shown in the following diagram.

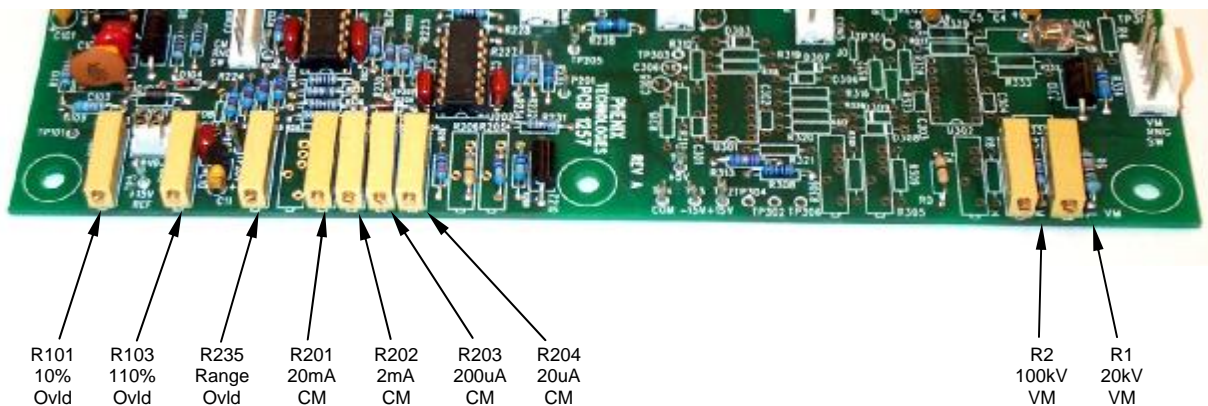

### 1. Output Voltmeter

Connect a precision high voltage voltmeter across the output to ground on low range. Raise the output to approximately 80% of range. Adjust the reading on the panel meter (M1) by means of potentiometer R1 to a corresponding reading. Check Linearity and calibration at various other main points of the range such as 20%, 40%, 60%, 100%. Repeat for High range, adjusting R2.



## CALIBRATION

### 2. Output Currentmeter

It is necessary to connect adequately rated High Voltage loads (isolated from ground) to the high voltage unit that will allow each full range current to be drawn at approximately 15% or higher output voltage. This allows sufficient resolution to adjust current levels.

Place Binding Post Configuration in GUARD MODE. (Jumper clip is installed between Guard and Ground posts.)

Connect a precision ammeter between the low potential side of the appropriate high voltage load and the Return post. Select the low current meter range (20uA). Raise the output to approximately 80% of range (16uA). Adjust the reading on the panel meter (M1) by means of potentiometer R204 to the corresponding reading of the standard meter. Repeat for 200uA, 2mA, and 20mA ranges; adjusting R203, R202, and R201 respectively. (High Voltage load will need to change when changing range).

An optional method is to use DC current injection between "RTN" and "GND" (Guard Mode). **If using this method, do not turn High Voltage ON!**

### 3. Overcurrent

This calibration should not need adjustment (factory adjusted). If the overcurrent circuit is out of calibration, perform the following steps.

- a. With unit off, short the output terminal to ground through an appropriate currentmeter. (A High Voltage Load will give better resolution and make calibration easier and more accurate. Minimum recommended resistance: 100K ohm, 100 watt.).
  - b. Set the Current Trip potentiometer on the front panel to "1 and the current range switch to 20mA.
  - c. Turn on HV On and adjust the output current slowly until 10% of rated current (2mA) is displayed on the currentmeter.
  - d. Adjust potentiometer R101 until the Reset lamp illuminates and high voltage is shut off.
  - e. Set the Current Trip potentiometer on front panel to "11".
  - f. Turn on HV On and adjust the output current slowly until 110% of rated current (22mA) is displayed on meter.
  - g. Adjust potentiometer R103 until the Overload lamp illuminates and high voltage is shut off.
  - h. Repeat step "B" through "G" as necessary until both settings are calibrated.
4. Range Overcurrent. R235 sets an overcurrent for the ranges and should be set to trip at approximately 112% of 2mA range.

## TROUBLESHOOTING

### General

If the controls do not operate properly after having been used according to the instructions, the following hints may help.

- Check main facility input power to the test set.
- Check indicating lamps. (Spare lamps are available through Phenix Technologies.)
- Check fuse-F1.
- Check all external plug connections on the test set.

**Specific Problems**, Refer to appropriate electrical diagrams.

1. High Voltage cannot be turned on?
  - Voltage Control dial is not in Zero Start position.
  - External interlock circuit open.
  - Current Trip setting too low, or needs reset.
  - Current trip circuit damaged, won't reset, try replacing U101 (LM311N)
  - Faulty HV On switch, faulty HV Off switch.
  - Relay K1 dislodged or faulty.
  
2. Voltage control inoperable?
  - Tripped or faulty Thermal Overload.
  - High voltage is not on (see number 1 above).
  - Faulty Variable transformer "T1".
  - Faulty High Voltage tank assembly.
  
3. Over current inoperable?
  - Faulty U101 (LM311N).
  - Faulty DC Power Supply circuit.
  - Defective over current relay K101.
  - Faulty R7 over current trip potentiometer.
  
4. Currentmeter inoperable?
  - Improper connection of GUARD/GND/RETURN jumper (J1) for mode of operation.
  - Improper connection of test specimen.
  - Faulty U201 or U202 (LM348).
  - Meter damaged.
  - Faulty currentmeter range switch SW5.
  - Faulty connection in currentmeter circuit.
  - Faulty DC Power Supply Circuit.
  
5. Voltmeter inoperable?
  - Meter damaged.
  - No high voltage present at output.
  - Faulty connection in voltmeter circuit.

## TROUBLESHOOTING

6. No output voltage from high voltage section?
  - Defective metering circuit.
  - No input to voltage regulator section, possible problems with K1 relay or Thermal Overload.
  - High Voltage Cable shorted to shield of cable.
  - Faulty High Voltage Unit.

## STORAGE OF EQUIPMENT

If the equipment will be stored for a prolonged period, the following precautions are recommended.

1. The equipment should be covered and kept in a warm, dry environment (95% maximum humidity, 5 to 50° Celsius).
2. In no case should the test unit be stored outdoors (unless previously specified in the original purchase agreement).

CIRCUIT DIAGRAM SYMBOLS  
SYMBOLS POUR SCHEMA DE CIRCUIT  
SYMBOLE ZU SCHEMA

REF	SYMBOL	DESCRIPTION	DESCRIPTION	BEMENKUNG
A		Amplifier	Unite d'amplificateur	Verstärker
ARSR		Surge Arrestor	Parafoudre	Ueberspannungsableiter
C		Capacitor	Condensateur	Kondensator
BSHG		Bushing	Tranversée	Durchfuehung
C		Electrolytic Capacitor	Condensateur électrol	Eleckrolytik kondensator
F		Fuse	Fusible	Sicherung
CT		Current Transfomer	Transformateur de Courant	Stromtransformer
CB		Circuit Breaker	Intérupteur	Unterbrecher
K		Relay, Contactor	Relais, Contacteur	Relais, Schütz
L		Inductor	Self	Drossel, Spule
MOT		Motor	Moteur	Motor
MOV		Movistor	Parafoudre	Movistor
NE		Neon	Parafoudre	Ueberspannungsableiter
LP		Lamp, Indicator	Lampe	Meldeleuchte
R		Resistor	Resistance	Widerstand
R		Variable Resistor	Resistance Variable	Widerstand
T		Transformer	Transformateur	Transformer
TB		Terminal Block	Borne	Lösbare Klemme
X		Connector	Prise de Courant	Steckverbindung
K		Relay Contact Normally Open	Contact Normalement Ouvert	Schlierskontakt
K		Relay Contact Normally Closed	Contact Normalement Fermé	Oeffnungskontakt
K		Changeover Contact	Contact de Changement	Umschaltkontakt
		Shielded Wire	Cable blindé	Abgeschirmetes Kabel
TR		Transistor	Transisteur	Transistor
M		Analog Meter	Insrument Analogue	Analog Meter
D		Diode	Diode	Diode
Z		Zener	Diode Zener	Zener
SCR		Thyristor	Thyristor	Thyristor
SW		Normally Open Maintained Switch	Interrupteur Normalement Maintenu Ouvert	Schrittschalter (Schliesser)
SW		Normally Closed Maintained Switch	Interrupteur Normalement Maintenu Fermé	Schrittschalter (Oeffner)
SW		Normally Closed Momentary Switch	Interrupteur Normalement Fermé Momentanement	Druckschalter (Oeffner)
SW		Normally Open Momentary Switch	Interrupteur Normalement Ouvert Momentanement	Druckschalter (Schliesser)
DP		Current Overload Device	Dispositif De Sûr Intensité	UeberstromschutzEinheit

**THIS PAGE  
INTENTIONALLY  
LEFT BLANK.**

## 4100-10 RECOMMENDED SPARE PARTS

Phenix Technologies recommends that the customer purchase and stock the following parts for normal maintenance of the unit. The recommended quantity should be sufficient to support the unit during normal operation.

If the unit will be operated at an isolated site for an extended period or will be subjected to unusual stresses, a larger quantity of parts should be stocked as spares. In such cases, contact Phenix Technologies for a recommendation.

Current prices may be obtained by contacting the Parts Ordering Department at Phenix Technologies.

<u>Part Name</u>	<u>Computer Number</u>	<u>Recommended Quantity</u>
Digital Panel Meter, 3 ½ Digit LCD, 2V (M1,2)	1506400	1
Analog 1 ½" Charging Current Meter (M3)	1501016	1
Lamps, 60 V, EAO	1420150	5
EAO Momentary – 1 POLE Switch (SW 2,34)	1860120	1
Limit Switch (SW7)	1866005	1
LM311N Comparator IC (U101)	1794493	2
OP400GP OP AMP (U201, 202)	1794105	2
Relay, Control (K1)	1700610	1
Fuse, 1 A, 250 V, (F1)	1603601	1
Power Input Cord	1077167	1
Binding Post- RED	1351102	1
Binding Post - GREEN	1351103	1
Binding Post - WHITE	1351104	1
High Voltage Cable Assy.	30070015	1
Return Cable Assy.	30080010	1
Ground Cable Assy.	30080011	1

## 4100-10 PARTS LIST

ITEM	DESCRIPTION	QTY	PART NO.
<b>CONTROLS</b>			
C1, 4	47uF 20V Capacitor	2	1096510
C2	4.7Uf, 35V Capacitor	1	1095010
C3	1 uF 50V Capacitor	2	1094051
C5, 6,10	.033 uF 630v Capacitor	3	1093300
CABLE-GROUND	20 FT. GROUND CABLE ASSY.	1	30080011
CABLE-HV	20 FT. HV CABLE ASSY.	1	30070015
CABLE-RTN	20 FT. RED RETURN CABLE ASSY.	1	30080010
CB1	CIRCUIT BREAKER, 10 AMP, 2-POLE	1	1601314
CORD	INPUT POWER CORD	1	1077167
F1	FUSE, 1 AMP	1	1603601
F1	FUSE HOLDER	1	1603920
J1	BINDING POST, RED	1	1351102
J2	BINDING POST, GREEN	1	1351103
J3	BINDING POST, WHITE	1	1351104
J1-3	SHORTING BAR	1	1351110
K1	RELAY-3 POLE 120 VAC COIL	1	1700610
K101	RELAY – 2 POLE 12 VDC COIL	1	1701033
LP1 LENS	CLEAR LENS EAO	1	1422153
LP2 LENS	LENS, RED EAO	1	1422150
LP3 LENS	LENS, GREEN EAO	1	1422151
LP4 LENS	LENS, BLUE EAO	1	1422148
LP1 SOCKET	LAMP SOCKET EAO	1	1423300
LP1-4	LAMP 60V EAO	4	1420150
M1, M2	METER-DIGITAL, 3 ½ DIGIT LCD	2	1506400
M1-CM	METER PROTECTION BOARD ASSY.	1	31126500
M2-VM	METER PROTECTION BOARD ASSY.	1	31126502
M3	METER-ANALOG 1 ½"	1	1501016
MOV1, 2	MOVISTOR, V130LA10A	2	1606100
P1	POWER INPUT RECEPTACLE	1	1153328
PCB Assy.	PCB1257 Rev A METER/OVERLOAD BD	1	31125709
PCB	PCB 1223 (MTG FOR R1-R5)	1	1112231
R1, R2	RESISTOR, 750 OHM, .5W, 1%	4	1711900
R3	RESISTOR, 7.5K OHM, .5W, 1%	2	1712150
R4	RESISTOR, 75K OHM, .5W, 1%	2	1713500
R5	RESISTOR, 750K OHM, .25W, 1%	2	1725050
R6A	RESISTOR, 39K OHM, .25W, 1%	1	1722618
R6B	RESISTOR, 1.5 MEG OHM, .25W, 1%	1	1735140
R7	POTENTIOMETER, LINEAR, 10K, 2W	1	1761098
R7 DIAL	BLACK STATOR	1	1355905
R7 DIAL	0-11 NUMBERED DIAL	1	1355910
R7 KNOB	BLACK KNOB	1	1355101
R7 KNOB	KNOB CAP	1	1355102
SG1, 2	SPARK GAP-90V	2	1605110
SW/LP 2,3,4	SWITCH, PUSHBUTTON, MOMENTARY, 1-POLE	3	1860120
SW5	SWITCH, ROTARY, 3 POLE, 4 POS.-SH.	1	1863049
SW6	SWITCH, ROTARY, 2 POLE, 2-6POS.-SH.	1	1863047
SW5, 6 KNOB	KNOB, ¼"	2	1355310
SW7	SWITCH, ROLLER, CAM, ZERO START	1	1866005



## 4100-10 PARTS LIST

ITEM	DESCRIPTION	QTY	PART NO.
SX1	FEMALE 2 PIN CHASSIS CONN.	1	1151152
SX1	PIN-FEMALE 20GA	2	1151174
SX1 PLUG	MALE 2 PIN CABLE CONN.	1	1151162
SX1 PLUG	CABLE CLAMP	1	1151186
SX1 PLUG	CONTACT SOLDER PINS MALE	2	1151176
THERMAL OVERLOAD	PUSHBUTTON THERMAL CIRCUIT BREAKER-7A	1	1601420
T1	VARIABLE TRANSFORMER	1	1890120
T2 (220V UNITS)	TRANSFORMER, STEP DOWN, 230/115	1	1894433
U101	LM311N	1	1794493
U201, 202	OP400GP OP AMP	1	1794105
Z1-6	1-5KE18A TRANSORB	6	1780065
Z7, 8	1-5KE18C TRANSORB	2	1780069
	CASE	1	2100516
<b>HV UNIT</b> FOR HV UNIT INTERNAL PARTS, REFER TO HV DC TANK SCHEMATIC			

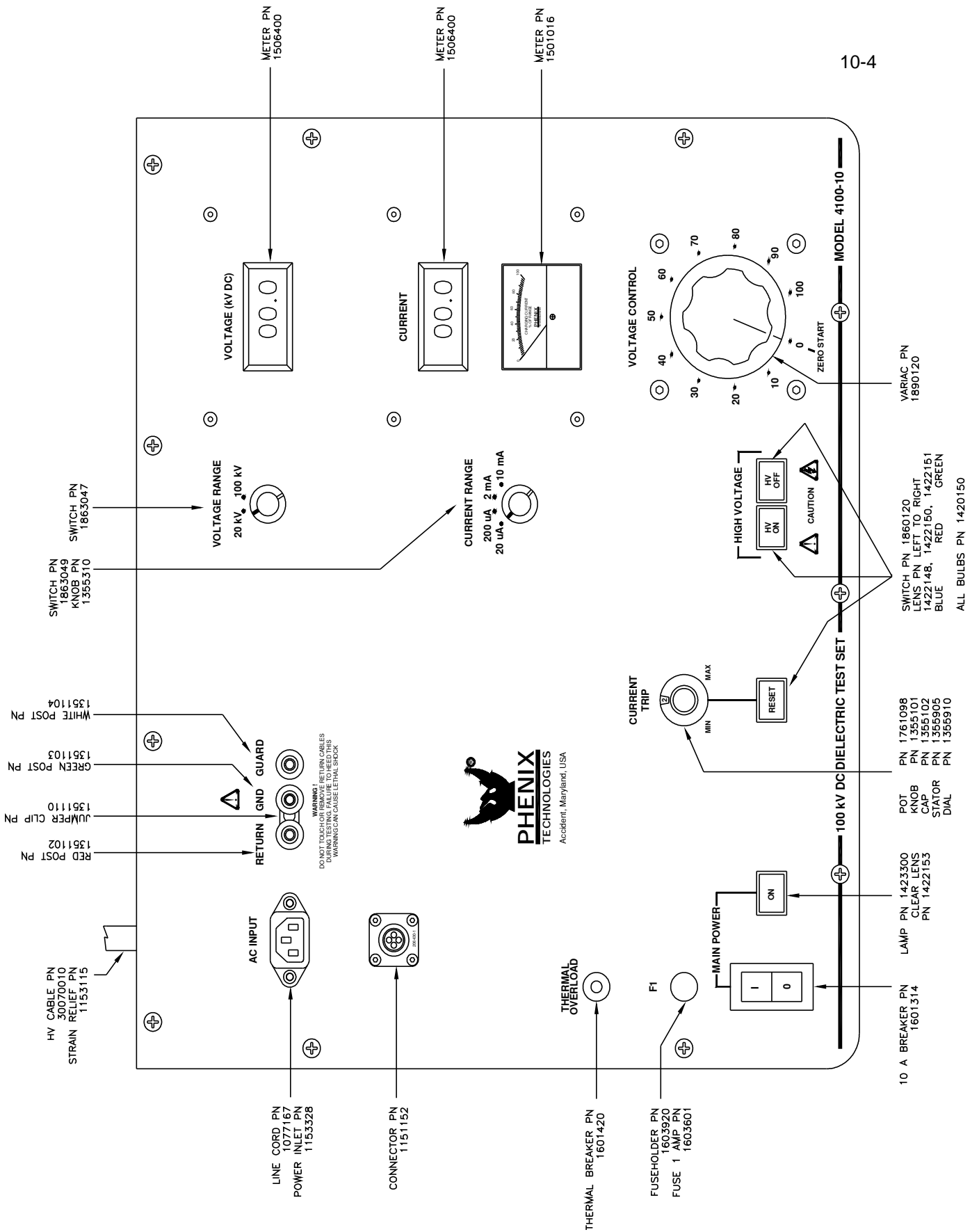

## PARTS ORDERING INFORMATION

Replacement parts are available from Phenix Technologies, Inc.

Changes to Phenix Technologies' products are sometimes made to accommodate improved components as they become available, and to give you the benefit of the latest technical improvements developed in our Engineering Department. It is, therefore, important when ordering parts to include the serial number of the unit as well as the part number of the replacement part. When your purchase order is received at our office, a representative of Phenix Technologies will contact you to confirm the current price of the part being ordered. If a part you order has been replaced with a new or improved part, an Applications Engineer will contact you concerning any change in part number.

Your order for replacement parts should be sent to:

Replacement Parts Department  
Phenix Technologies, Inc.  
75 Speicher Drive  
Accident, Maryland 21520

## RETURNED MATERIAL

If for any reason it should become necessary to return this equipment to the factory, the Service Department of Phenix Technologies, Inc. must be given the following information:

Name Plate Information  
Model Number  
Serial Number  
Reason for Return  
Cause of Defect

If Phenix Technologies, Inc. deems return of the part appropriate, it will then issue a "Authorization for Return".

If return is not deemed advisable, other inspection arrangements will be made.

NOTE: Material received at this plant without the proper authorization shall be held as "Customer's Property" with no service until such time as the proper steps have been taken.

Your cooperation is requested in order to ensure prompt service.

## ELECTRICAL DIAGRAMS

	<u>Drawing Number</u>	<u>Description</u>
1.	7410103 Rev B	4100-10 Control-Digital-PCB1257 Rev A
2.	7430101 Rev B	4100-10 HV DC TANK Schematic Rev A

NOTES:  
1) THE CONNECTIONS TO THE PCB ARE LABELLED PER THE FOLLOWING EXAMPLE: 4-5 EQUALS CON4, TERMINAL 5.

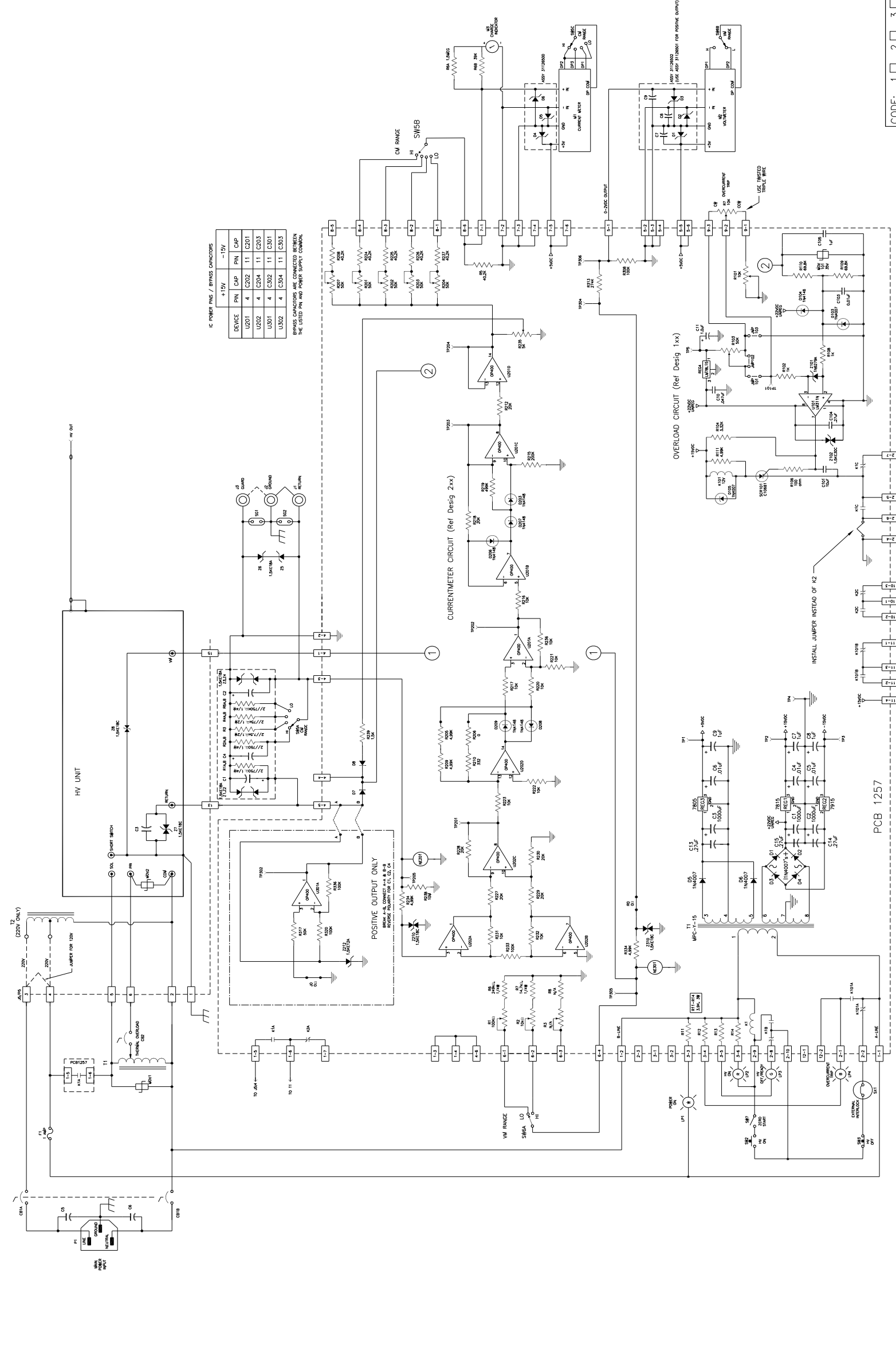

CODE: 1 2 3 4 N/A  
 DATE: PM: YES NO

PRODUCTION APPROVAL:  
 TOLERANCES  
 FABRICATION DIMENSIONS: ± 1/32"  
 MACHINING DIMENSIONS: ± 1/64"  
 UNLESS OTHERWISE NOTED

PHENIX TECHNOLOGIES  
 116 INDUSTRIAL DRIVE, ACCIDENT MD 21520  
 SCALE: N/A  
 TITLE: 4100-10 CONTROL - DIGITAL  
 DATE: 8/14/04  
 APPROVED BY: LEO

REVISIONS  
 ECN NO: B503  
 DATE: 3/31/05  
 BY: LEO  
 REMARKS: CHANGES FOR PCB 1257 REV A

PCB 1257  
 MODEL NO: 4100-10  
 SERIAL NO: N/A  
 DRAWING NO: 7410103  
 SHEET NO: 1/1

# BILL OF MATERIAL

4100-5 DC TANK ASSEMBLY

ITEM	QTY	DESCRIPTION	PART NO
C1-C2	2	0.008uF,50kV	1091800
CR1-2	2	150KV XRAY BD	1782500
R1-2	2	200 MEG	1748415
R3-4	2	150K, 2.9kJ	1744275
SOL1	1	SOLENOID -- DISCHARGE	1704207
T1	1	101-1300	38141300

NOTE: CR1-2 ARE REVERSED FOR POSITIVE OUTPUT UNITS

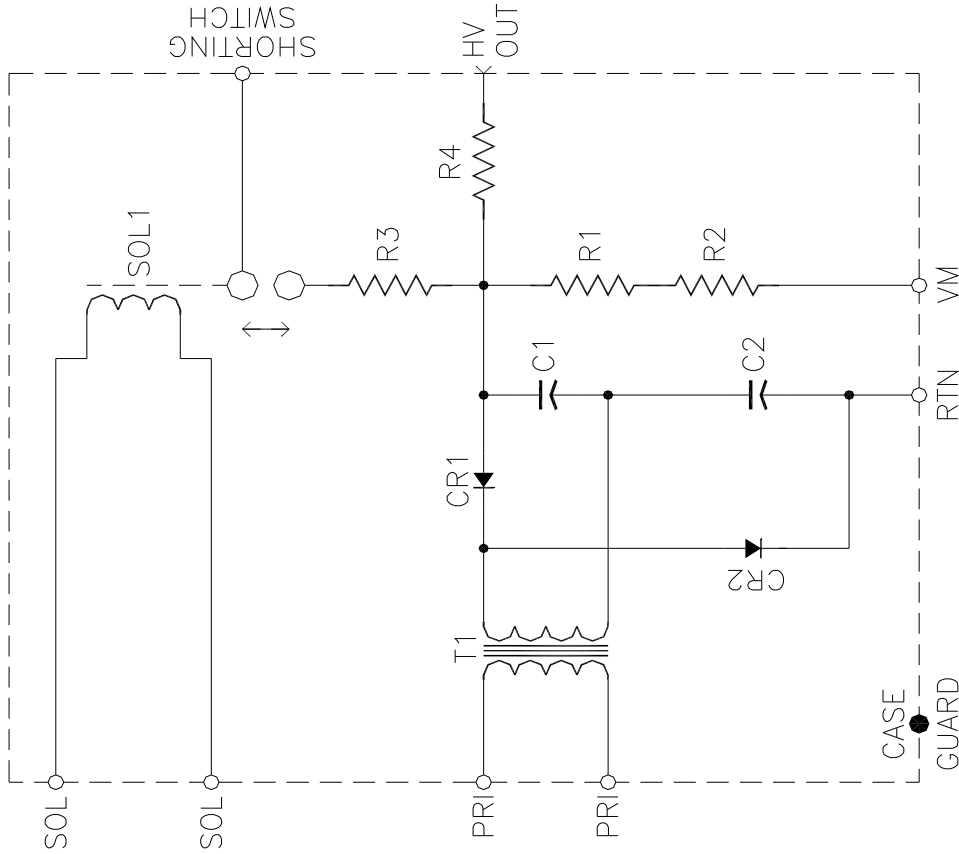

REVISIONS		PRODUCTION APPROVAL:		DATE:	PM: YES <input type="checkbox"/> / NO <input checked="" type="checkbox"/>
ECN NO	REMARKS	DATE	BY		
A) B525	CHANGED HIGH VOLTAGE DIODE SYSTEM	05/05/05	BJV		
B) B705	ADDED POSITIVE OUTPUT NOTE	3/10/06	LEO		
C)					
D)					
E)					

<b>PHENIX TECHNOLOGIES</b>		116 INDUSTRIAL DRIVE, ACCIDENT MD 21520	
SCALE: N/A	DO NOT SCALE	PATH: MASTERS\ACADDWGS\DC-DIELE\7430101	DESIGN BY: LEO
TITLE: HV DC TANK SCHEMATIC	4100-10	DATE: 8/25/04	DWN BY: BJV
SERIAL NO:	MODEL NO: 4100-10	DATE: 8/25/04	APVD BY: LEO
PAINT CODE: N/A	TEMPLATE NO: N/A	DWG NO: 7430101	SHEET: 1/1